



JMF612

SATA II to Flash Controller

Overview

JMF612 is a single chip, supports external SDRAM, one SATA II port and USB2.0 combo to NAND flash interface. It is native design to provide higher bandwidth for flash memory access.

JMF612 can support the maximum read and write speed to drive the limit of flash memory. JMF612 has the best supporting to the latest NAND flash memory, including Samsung, Toshiba, Hynix, Micron and IM Flash. It also provides the embedded hardware error correction code (ECC), wear leveling, and bad block management technology in this chip. In order to resolve compatibility issue, JMF612 provides the on line firmware upgrade ability.

JMF612 provides embedded processor, internal masked ROM, data SRAM, SATA link/transport layer, SATA PHY, USB 2.0 device controller and USB 2.0 PHY. Data swap between different interfaces can be done very efficiency by DMA without CPU involvement. Based on the efficient architecture, the JMF612 can provide the best performance.

Feature

Compliance

- Compliant with **Universal Serial Bus Specification Revision 2.0**
- Compliant with **USB Mass Storage Class specification version 1.0**
- Compliant with **Serial ATA International Organization : Serial ATA Revision 2.6**

USB 2.0

- USB Bulk Only transport protocol

SATA II

- Supports 1-port 3.0Gbps SATA II interface

CPU

- Embedded data buffer.
- 32bits Embedded processor.
- 32 KBytes Embedded masked program ROM.
- 128 KBytes Embedded system RAM

FLASH

- Support maximum 16CE's Flash per channel.
- Support 5x/4x/3x nm Flash.
- Enhanced endurance by dynamic/static wear-leveling.
- Supports 4K/8K bytes page size..
- Support SMART (Self-Monitoring, Analysis and Reporting Technology) function.
- Data integrity under power-cycling.



- Supports online SATA/USB firmware update.
- Supports 8 bits Flash interface.
- Supports BCH 16/24 bits ECC.
- 250/200 MBytes/sec Sequential read/write rates (MLC).
- 6000/10000 IOPS 4K random read/write rates (MLC).

SDRAM

- Support DDR/DDR2
- Support 128Mbits to 2Gbits

SYSTEM

- Integrated 1-port USB2.0, 1-port SATA II and 8-channel Flash controller
- LED indicator for USB2.0 or SATA read/write access
- LED indicator for USB2.0 or SATA PHY link up
- Provides 15 GPIO pins for customer
- Provides UART and JTAG for S/W debugging
- Available in 281-pin BGA(12 mm * 12 mm) package

Functional Block Diagram

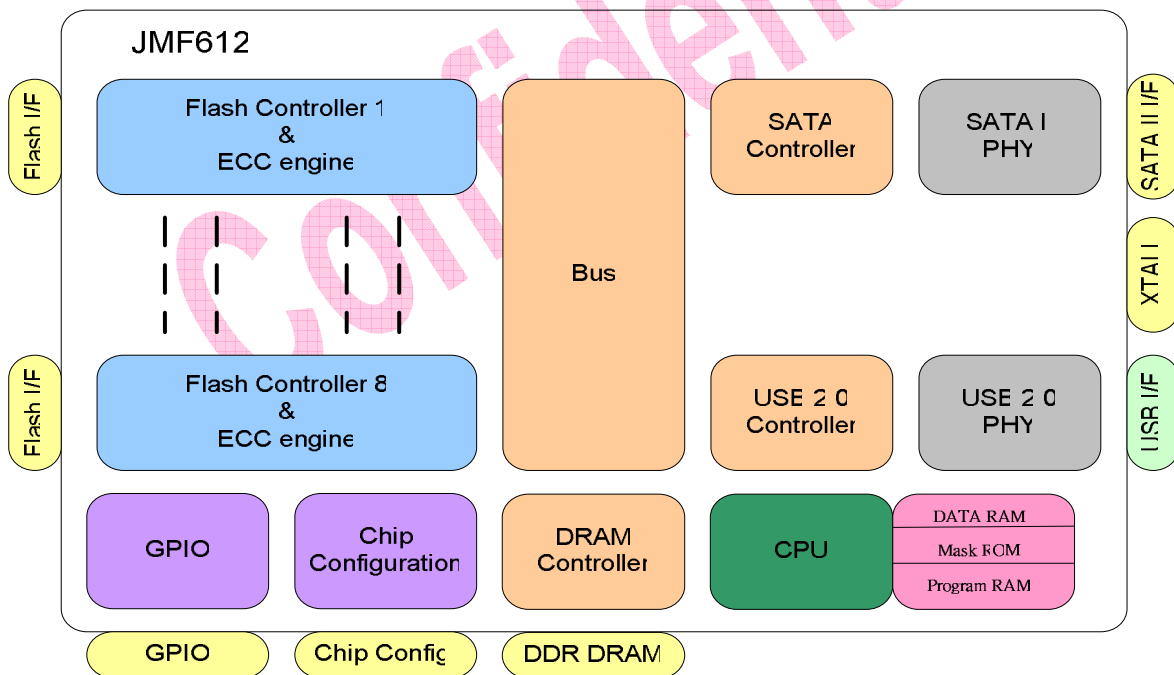

Contact Information

- Sales : sales@jmicron.com
- Tech. Support : fae@jmicron.com